

# CCD77 Back Illuminated

## 512 x 512 pixel full frame Scientific CCD Sensor

# Provisional

## Features

- ! 512 x 512 pixel image area
- ! Back Illuminated Format
- ! Inverted mode operation (MPP)
- ! 24  $\mu\text{m}$  Square Pixels
- ! Low Noise, high responsivity output amplifiers
- ! 100% Active Area

## Introduction

This version of the CCD77 family of CCD Sensors is a full frame device designed for scientific applications. Back illuminated technology in combination with low noise amplifier make the device well suited to general imaging. To further maximise the sensitivity the CCD is manufactured without anti-blooming structures.

The device has two serial output registers at the top and bottom of the chip. Each register has a single output at one end and a charge injection structure at the other end for test purposes.

This version of the CCD77 is manufactured in standard IMO format so that the charge can be transferred either up or down the device depending on which register is to be used.

## General Data

### Format

Image Area	(mm)	12.3 x 12.3
Active Pixels	(H)	512
	(V)	512
Pixel Size	( $\mu\text{m}$ )	24 x 24

15 additional pixels are provided for overscanning purposes on the output register.

Number of Output Amplifiers 2

The device has a 100% fill factor for maximum sensitivity.

### Package

Format	24 pin Ceramic DIL
Size	22.9 x 29.9mm
Inter pin spacing	2.54mm
Inter row spacing	22.86mm

### Typical Performance

O/P Amp Responsivity	( $\mu\text{V}/\text{e}^-$ )	2.8
Readout Noise (140-253K)	( $\text{e}^-$ rms)	3
Maximum Speed	(MHz)	6 MHz
Peak Signal	( $\text{e}^-/\text{pixel}$ )	300,000min
Peak Output Voltage	(V)	0.84
Dark Signal (at 293K)	( $\text{e}^-/\text{pixel}/\text{s}$ )	750

Charge Transfer Efficiency	(%)	
Parallel		99.9999
Serial		99.9993

Dark Sig Non-Uniformity (at 293K,  $\text{e}^-/\text{pixel}/\text{s}$ ) 300

Readout Register Capacity		600ke-
Minimum Spectral Range	(nm)	200 - 1100

Note: All values quoted using typical operating conditions at a readout frequency of 20 kHz and at a temperature of 253K (approx).

## Typical Operating Conditions

Ref.	Pin No.	Description	
V <sub>SS</sub>	7,18	Substrate	9.5V
If 1	23	Image Clocks (high level)	12V
If 2	21		
If 3	2		
Rf 1T	10	Top Register Clocks (high level)	12V
Rf 2T	9		
Rf 3T	4		
Rf 1B	15	Bottom Register Clocks (high level)	12V
Rf 2B	16		
Rf 3B	17		
f R	8	Reset Pulse (high level)	12V
V <sub>OG</sub>	5	Output Gate	3V
V <sub>OST</sub>	24	Output Source Top	See note 2
V <sub>OSB</sub>	12	Output Source Bottom	See note 2
V <sub>RD</sub>	14	Reset Drain	17V
V <sub>OD</sub>	11	Output Drain	29V
V <sub>IDT</sub>	1	Input Diode (Top)	See Note 4
V <sub>IDB</sub>	13	Input Diode (Bottom)	See Note 4
V <sub>TGT</sub>	3	Transfer Gate (Top)	See Note 1
V <sub>TGB</sub>	22	Transfer Gate (Bottom)	See Note 1
V <sub>IG</sub>	20	Input Gate	See Note 4
	6,19	No Connection	
R <sub>L</sub>		External Load Resistor	5-10kΩ

### Note 1

The transfer gate is a gate electrode between the image and register. For normal operation this should be clocked as If 3.

### Note 2

OS = 3 - 5 volts below OD typically.

### Note 3

Readout register clock pulse low levels +1V; other clock low levels 0 ± 0.5V.

### Note 4

For normal operation the input gate should be set to 0V and the input diodes to approximately 22V. To inject charge for test purposes the input gate should be pulsed high during the period when Rf 1 is high and ID should be adjusted to inject the required charge level.

### Note 5

With the If connections shown charge is transferred to the top register. In order to transfer charge to the bottom register If 2 and If 1 should be reversed.

## Blemish Specification

Grade	0	1	2
Column Defects-black or slipped -white	0	2	6
Black Spots	20	30	60
Traps > 200e <sup>-</sup>	2	5	10
White Spots	20	30	100

The minimum separation between adjacent column defects is 50 pixels.

## Outline

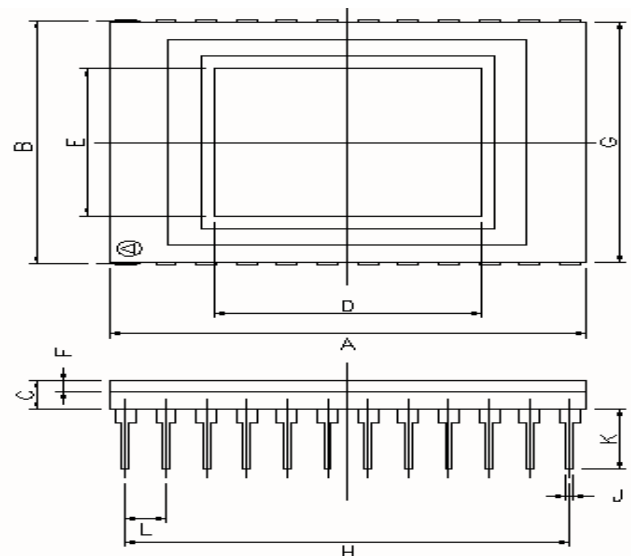

Ref.	Millimetres	Ref.	Millimetres
A	29.94 ± 0.30	G	22.61 ± 0.25
B	22.86 ± 0.25	H	27.94 ± 0.13
C	2.70 ± 0.27	J	0.46 ± 0.05
D	16.80 ± 0.05	K	5.60
E	13.86 ± 0.05	L	2.54 ± 0.13
F	1.05 ± 0.50		